



## Euro(designer) Pen Assembly Instructions

### KIT FEATURES

- Heavy 24kt gold plating with epoxy coating.
- Engineered to match other Penmaking Designer Mont Blanc Style Products.
- Smooth operating twist mechanism.
- Uses Cross® Style Ball Point Refill.
- Overall length: 5-9/16".

### REQUIRED ACCESSORIES

- 7mm, long mandrel
- 7mm drill bit
- 3 pcs. designer pen bushings
- 7mm barrel trimmer (optional).
- 7mm drill guide (optional).
- 2 part epoxy glue or Super Glue

### Diagram A / Parts List & Layout

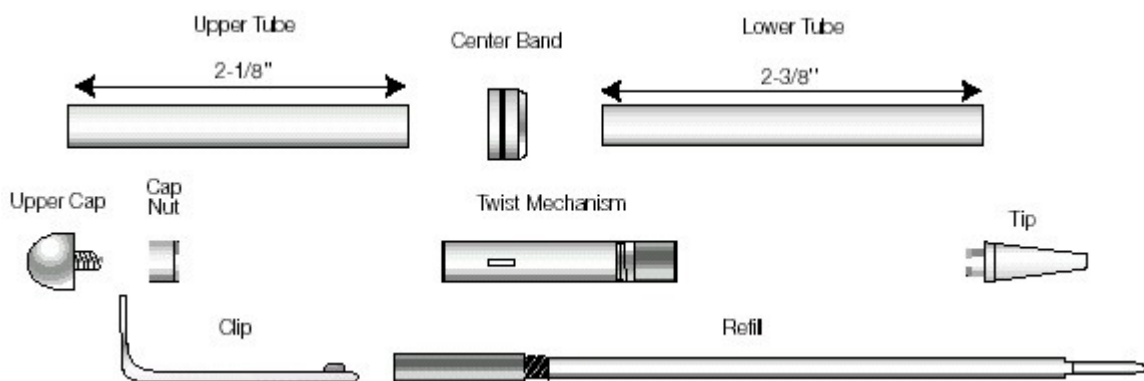

### Preparing the Blanks

- Cut 5/8" square blanks, to the length of the brass tubes (add 1/16" for squaring off).
- Drill a 7mm centered hole lengthwise through each blank.

- Spread glue over the tubes. Insert the tubes into the blanks with a twisting motion to spread the glue evenly inside. Center the tubes lengthwise inside the blanks.
- When the glue dries, square the ends of the blanks. Use a 7mm barrel trimmer or belt/disc sander to take the wood down flush to the brass tube.

## Diagram B / Turning The Blanks

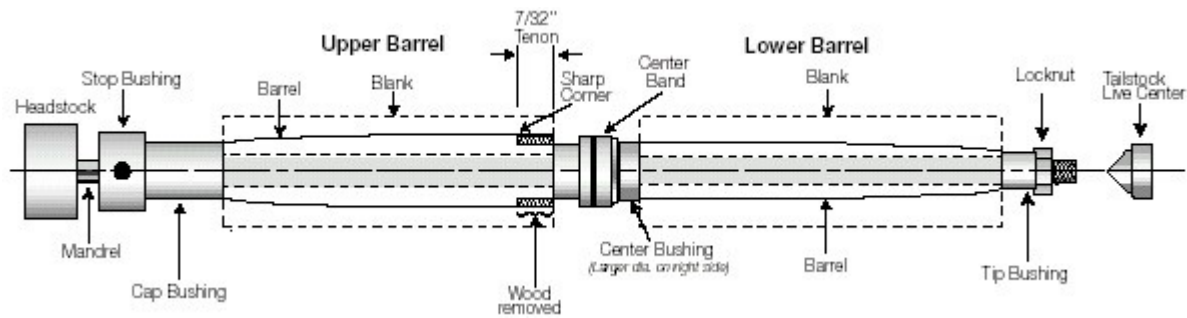

## Turning the Blanks

- Place the stop bushing onto the mandrel. Place the cap bushing next on the mandrel, then slide on the upper blank. Place the center band or a scrap band over the center bushing, square end of band toward cap. Place this on mandrel. Use tape to hold the center band against the lower blank. Place lower blank against the center bushing, next, slide on the tip bushing, thread the lock nut hand tight. Bring the tailstock snug with the mandrel. (Do not over tighten, it could damage the mandrel). Slide the stop bushing towards the blank, adjusting to remove spaces, then tighten the screw set and lock nut.
- Turn the wood down to the bushings and the diameter of the center band with chisels and sand paper. Taper the end cap and tip ends of the blanks (follow diagram C for profile) to conform with the cap and tip. Remove tape and use the outside dia. of the band to determine the outside diameter of the upper blank.

Be sure the wood on the lower blank next to center bushing does not exceed the bushing diameter, it may cause the twisting mechanism to jam when parts are engaged. Sand down to the final size.

## Cutting the Tenon

- Keep the center band away from the upper barrel. Make a pencil mark  $7/32$ " from end. Use a parting tool to cut a  $7/32$ " tenon down to the diameter of the bushing. Use the center band by sliding it over tenon to archive a good snug fit. Make sure you keep a sharp outside  $90^\circ$  corner on the tenon.
- Finish, polish and wax both barrels. Use a finish of your choice but be careful if brushing on a poly, etc. You can stick the tube, bushings, and mandrel together. You could also use Hut Perfect Pen Polish to achieve a bright, hard finish.

### Diagram C - Assembly

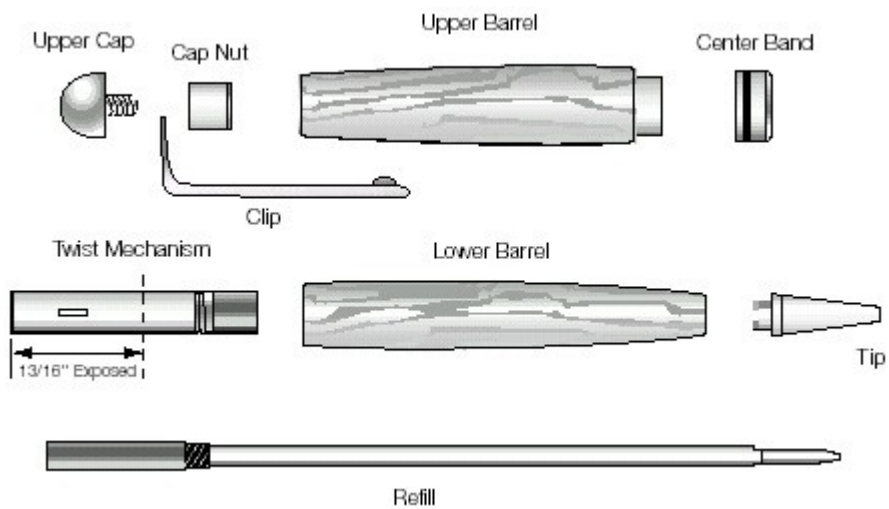

#### Assembly

- Line up finished parts according to diagram C.
- To press parts together, use a vice or a clamping instrument with wooden jaws. Press with caution, to avoid cracking the wood or scratching gold plated parts.

#### Upper Barrel

- Press the cap nut (recessed end first) into the tapered end of the barrel.
- Use a drop of glue around the tenon, slide center band (square end first) over the tenon. Push in, let dry.
- Insert the cap thread into the hole in the clip. Screw together tightly into cap nut.

#### Lower Barrel

- Press tip into the tapered end of the barrel.
- Scribe a line /mark on the twist mechanism 13/16" line from the chrome end. Press with the brass end of the mechanism first into the opposite end of the barrel to the line scribed. Leaving 13/16" exposed.
- Twist the mechanism and pen barrel to check the retracting and extension of the refill. Press the mechanism further in if necessary.
- Insert refill into twist mechanism and screw to the end.
- Engage and push barrels together.
- Pen operates by twisting the barrels to extend or retract writing tip.

### Diagram D - Bushing Set

