

MAGNUM

I N D U S T R I A L

MODEL NO.: MI-92300A \ MI-92302

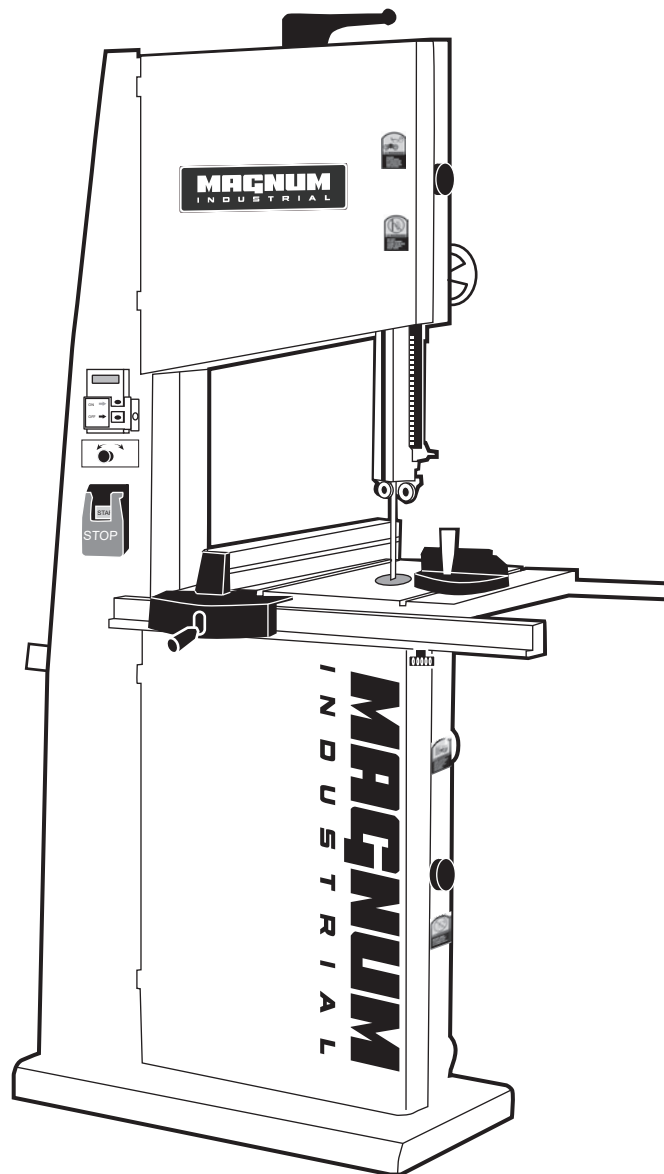

OPERATING MANUAL

SAFETY RULES

WARNING: FAILURE TO FOLLOW THESE RULES MAY RESULT IN SERIOUS PERSONAL INJURY.

- 1. FOR YOUR OWN SAFETY, READ INSTRUCTION MANUAL BEFORE OPERATING THE TOOL.** Learn the tool's application and limitations as well as the specific hazards peculiar to it.
- 2. KEEP GUARDS IN PLACE** and in working order.
- 3. ALWAYS WEAR EYE PROTECTION.** Wear safety glasses. Everyday eyeglasses only have impact resistant lenses; they are not safety glasses. Also use face or dust mask if cutting operation is dusty. These safety glasses must conform to ANSI Z87.1 requirements.

Note: Approved glasses have Z87 printed or stamped on them.

- 4. REMOVE ADJUSTING KEYS AND WRENCHES.** Form habit of checking to see that keys and adjusting wrenches are removed from tool before turning it on.
- 5. KEEP WORK AREA CLEAN.** Cluttered areas and benches invite accidents.
- 6. DON'T USE IN DANGEROUS ENVIRONMENT.** Don't use power tools in damp or wet locations, or expose them to rain. Keep work area well lighted.
- 7. KEEP CHILDREN AWAY.** All visitors should be kept safe distance from work area.
- 8. MAKE WORKSHOP KID PROOF** with padlocks, master switches, or by removing starter keys.
- 9. DON'T FORCE TOOL** it will do the job better and safer at the rate for which it was not designed.
- 10. USE RIGHT TOOL.** Don't force tool or attachment to do a job for which it was not designed.
- 11. USE PROPER EXTENSION CORD.** Make sure your extension cord is in good condition. When using an extension cord, be sure to use one heavy enough to carry the current your product will draw. An undersized cord will cause a drop in line voltage resulting in loss of power and overheating. Table 1 shows the correct size to use depending on cord length and nameplate ampere rating. If in doubt, use the next heavier gage. The smaller the gage number, the heavier the cord.
- 12. WEAR PROPER APPAREL** Do not wear loose clothing, gloves, neckties, rings, bracelets, or other jewelry which may get caught in moving parts. Nonslip footwear is recommended. Wear protective hair covering to contain long hair.
- 13. ALWAYS USE SAFETY GLASSES.** Also use face or dust mask if cutting operation is dusty. Everyday eyeglasses only have impact resistant lenses, they are NOT safety glasses.
- 14. SECURE WORK.** Use clamps or a vise to hold work when practical. It's safer than using your hand and it frees both hands to operate tool.
- 15. DON'T OVERREACH.** Keep proper footing and balance at all times.
- 16. MAINTAIN TOOLS WITH CARE.** Keep tools sharp and clean for best and safest performance. Follow instructions for lubricating and changing accessories.

17. **DISCONNECT TOOLS** before servicing; when changing accessories, such as blades, bits, cutters, and the like.
18. **REDUCE THE RISK OF UNINTENTIONAL STARTING.** Make sure switch is in off position before plugging in.
19. **USE RECOMMENDED ACCESSORIES.** Consult the owner's manual for recommended accessories. The use of improper accessories may cause risk of injury or persons.
20. **NEVER STAND ON TOOL** Serious injury could occur if the tool is tipped or if the cutting tool is unintentionally contacted.
21. **CHECK DAMAGED PARTS.** Before further use of the tool, a guard or other part that is damaged should be carefully checked to determine that it will operate properly and perform its intended function-check for alignment of moving parts, binding of moving parts, breakage of parts, mounting, and any other conditions that may affect its operation. A guard or other part that is damaged should be properly repaired or replaced.
22. **DIRECTION OF FEED.** Feed work into a blade or cutter against the direction of rotation of the blade or cutter only.
23. **NEVER LEAVE TOOL RUNNING UNATTENDED. TURN POWER OFF.** Don't leave tool until it comes to a complete stop.
24. **MAKE SURE TOOL IS DISCONNECTED** from power supply while motor is being mounted, connected or reconnected.

SAVE THESE INSTRUCTIONS

ADDITIONAL SAFETY RULES FOR BAND SAWS

1. If you are not thoroughly familiar with the operation of band saws, obtain advice from your supervisor, instructor or other qualified person.
2. Follow all wiring codes and recommended electrical connections. Make certain that the tool is properly grounded.
3. Make all adjustments with the power "OFF"
4. Always maintain proper adjustment of blade tension, blade guides, and blade support bearings.
5. Avoid awkward hand positions. A sudden slip could allow the hand to contact the blade.
6. Do not attempt to saw stock that does not have a flat surface, unless a suitable support is used.
7. Make sure blade is not contacting the workpiece before turning on the power switch.
8. Always keep hands and fingers away from the blade when the machine is running.
9. Hold workpiece firmly against table and feed into blade at a moderate speed.
10. Make sure that the saw blade teeth point downward toward the table.
11. Adjust upper guide to just clear work piece.

12. Disconnect machine from the power source when making repairs.
13. Replace all guards after servicing.
14. Turn off band saw if the material is to be backed out of an uncompleted cut.
15. Make relief cuts before cutting long curves.
16. Do not cut material that is too small to be safely supported.
17. Support long heavy work from the floor.
18. Before leaving the machine, make sure the work area is clean.
19. Important: When the tool is not in use , the switch should be in the “OFF” position and the power cord disconnected.
20. Do not remove jammed cutoff pieces until blade has stopped.
21. ON-OFF SWITCH PADLOCK – To safeguard the band saw from unauthorized operation and to avoid accidental starting by children or other not qualified to use, the use of padlock is required. To lock out the on – off switch, open the padlock, insert through the hole of the switch on button and close the padlock. Place the key in a location that is inaccessible to children and other not qualified to use the tool.
22. SWITCH WITH KEY – The switch key must be inserted into the switch before saw can operate. To lock the switch in the OFF position, remove the switch key from the switch. Place the key in a location that is inaccessible to children and others not qualified to use the tool.

GROUNDING INSTRUCTIONS

1. All grounded, cord-connected tools:

In the event of a malfunction or breakdown, grounding provides a path of least resistance for electric current to reduce the risk of electric shock. This tool is equipped with an electric cord having an equipment-grounding conductor and a grounding plug.

The plug must be plugged into a matching outlet that is properly installed and grounded in accordance with all local codes and ordinances.

Do not modify the plug provided – if it will not fit the outlet, have the proper outlet installed by a qualified electrician.

Improper connection of the equipment-grounding conductor can result in a risk of electric shock. The conductor with insulation having an outer surface that is green with or without yellow stripes is the equipment-grounding conductor. If repair or replacement of the electric cord or plug is necessary, do not connect the equipment-grounding conductor to a live terminal.

Check with a qualified electrician or service personnel if the grounding instructions are not completely understood, or if in doubt as to whether the tool is properly grounded.

Use only 3-wire extension cords that have 3-prong grounding plugs and 3-pole receptacles that accept the tool’s plug.

Repair or replace damaged or worn cord immediately.

2. Grounded, cord-connected tools intended for use on a supply circuit having a nominal rating less than 150 volts:

This tool is intended for use on a circuit that has an outlet that looks like the one illustrated in Sketch A in Figure 1. The tool has a grounding plug that looks like the plug illustrated in Sketch A in Figure 1. A temporary adapter, which looks like the adapter illustrated in Sketches B and C, may be used to connect this plug to a 2-pole receptacle as shown in Sketch B if a properly grounded outlet is not available. The temporary adapter should be used only until a properly grounded outlet can be installed by a qualified electrician. The green-colored rigid ear, lug, and the like, extending from the adapter must be connected to a permanent ground such as a properly grounded outlet box.

3. Grounded, cord-connected tools intended for use on a supply circuit having a nominal rating between 150-250 volts, inclusive:

This tool is intended for use on a circuit that has an outlet that looks like the one illustrated in Sketch D in Figure 1. The tool has a grounding plug that looks like the plug illustrated in Sketch D in Figure 1. Make sure the tool is connected to an outlet having the same configuration as the plug. No adapter is available or should be used with this tool. If the tool must be reconnected for use on a different type of electric circuit, the reconnection should be made by qualified service personnel; and after reconnection, the tool should comply with all local codes and ordinances.

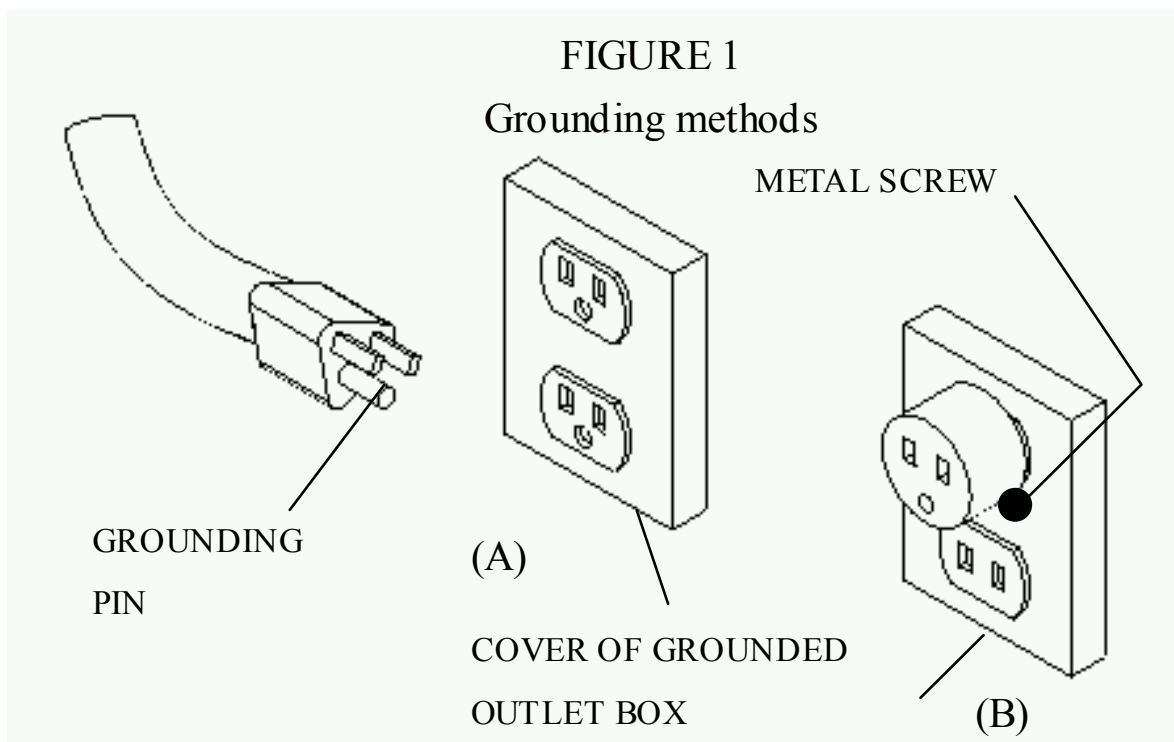

Note : In Canada, the use of a temporary adaptor is not permitted by the Canadian Electrical Code.

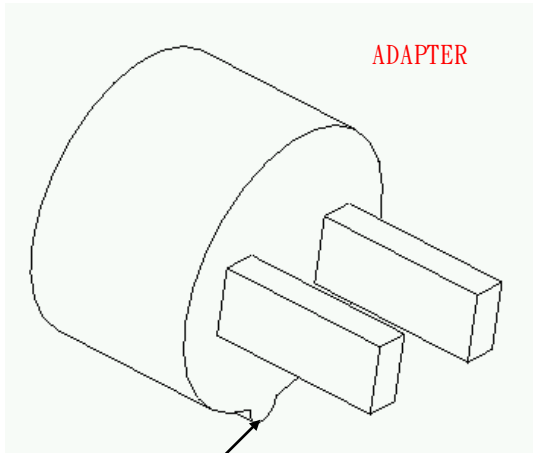

GROUNDING
MEANS

(C)

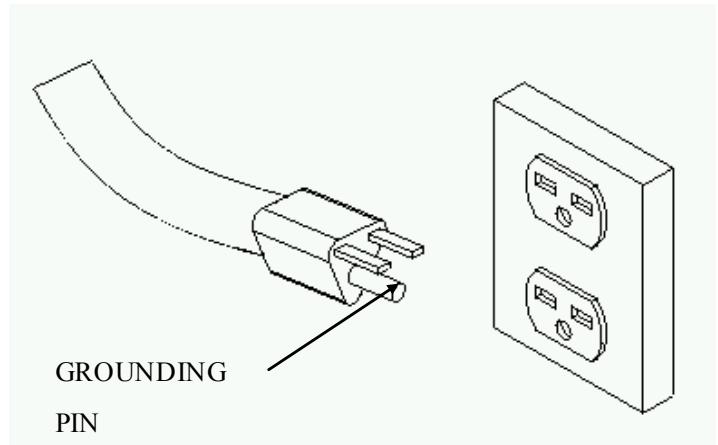

GROUNDING
PIN

(D)

Ampere Rating	Volts		Total length of cord in feet			
	120V	240V	25ft.	50ft.	100ft.	150ft.
Not						
More Than	More Than		AWG			
0	6		18	16	16	14
6	10		18	16	14	12
10	12		16	16	14	12
12	16		14	12	Not Recommended	

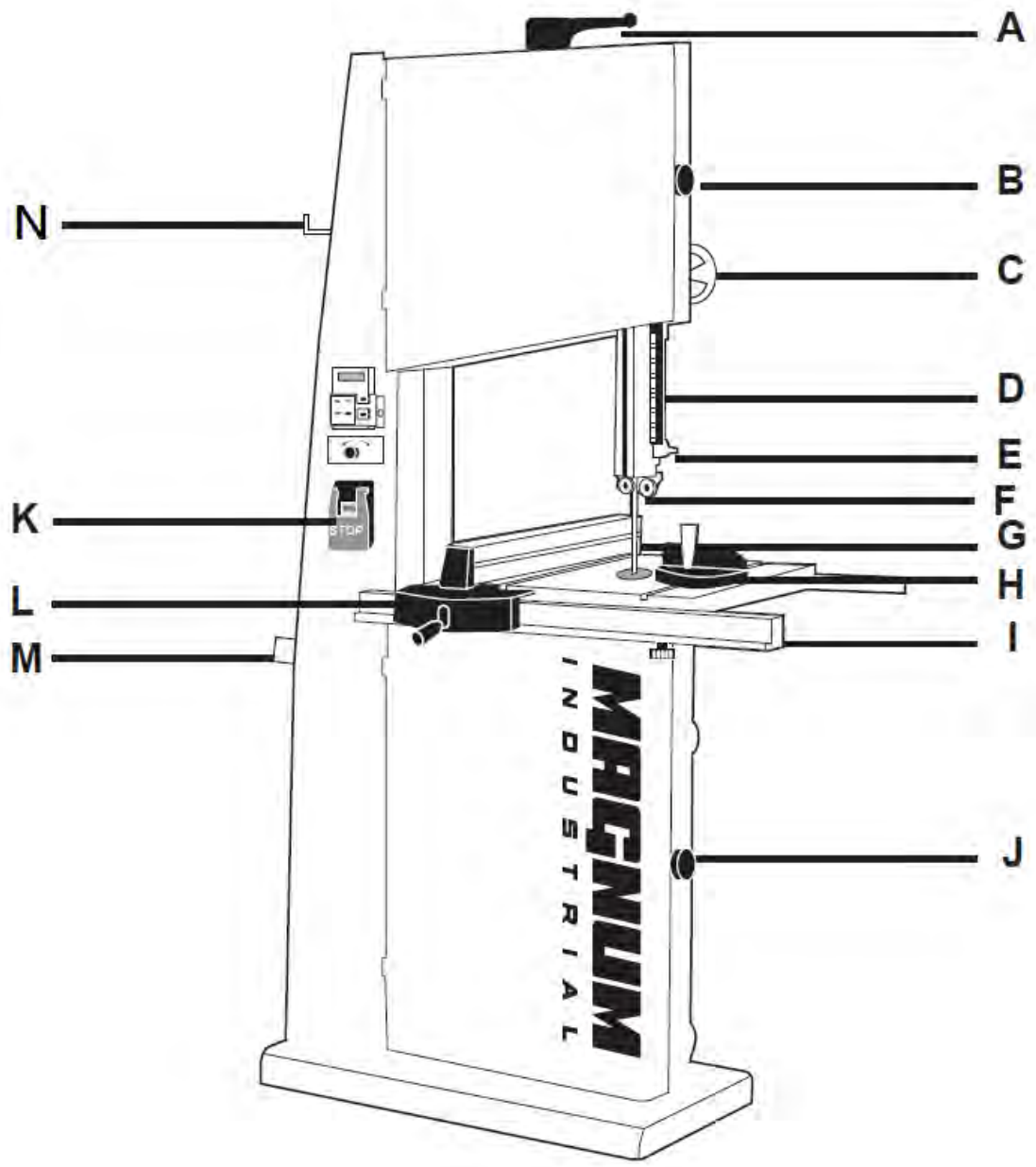

A:	QUICK RELEASE HANDLE	H:	MITER GUAGE
B:	UPPER DOOR KNOBE	I:	FENCE RAIL
C:	GUARD CONTROL HANDWHEEL	J:	LOWER DOOR KNOBE
D:	BLADE GUARD	K:	ON / OFF SWITCH
E:	BLADE THRUST BEARING	L:	FENCE
F:	BEARING GUIDE	M:	TOOL STORAGE (MI-92300A-086)
G:	BLADE	N:	HOLDER (MI-92300A-085)

Quick release / blade tensioning

Lifting the quick release handle to release blade tension. Remove blade and replace with new one. Turn down the handle to tighten blade.

Turn the handle clockwise to minor tighten blade tension and counterclockwise to release blade tension.

A blade under tension may also pull drive wheel out of alignment. Adjust alignment of drive wheel with tracking knob.

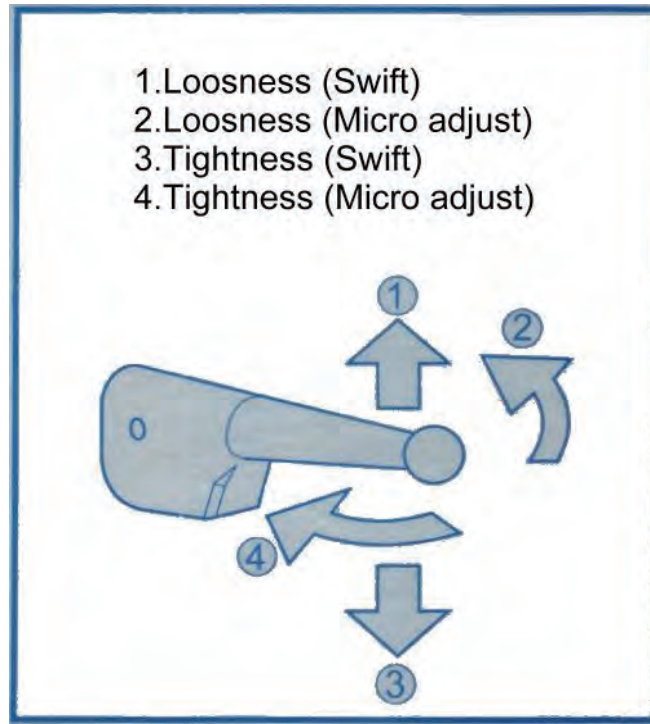

INSTALLATION OF FENCE

The image above shows the positioning of the mounting brackets when properly installed to the table (front and rear brackets are installed at opposite sides of the table).

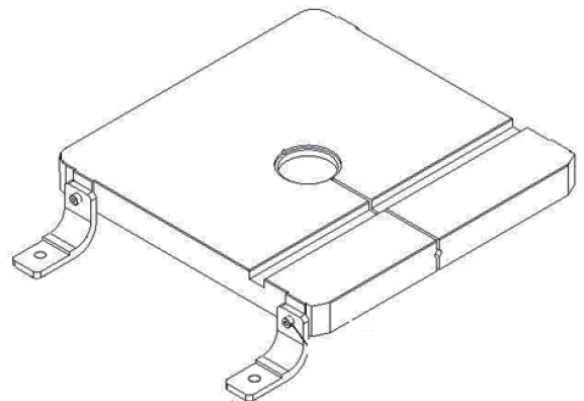

Place the bolts, washers, lock washers and hex nuts as shown above to attach the mounting brackets (front and rear) to the table. Don't tighten the nuts yet.

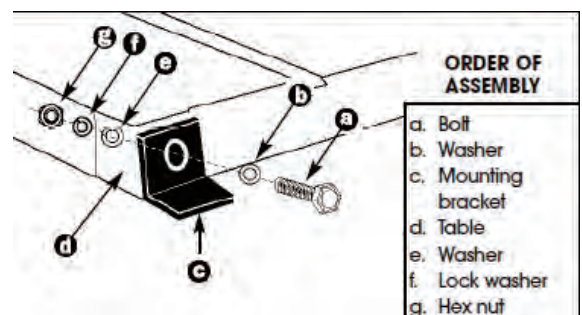

Install a 5/16" screw A , a flat washer B , and a square nut C on both front mounting brackets.

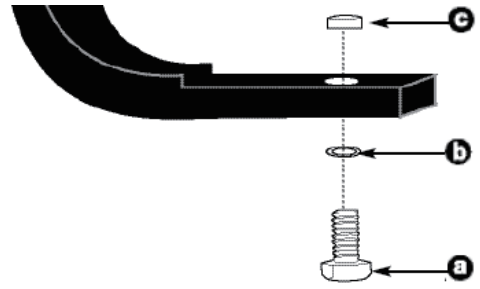

Install a 5/16" x 5/8" lock knob A and a square nut B on both rear mounting brackets.

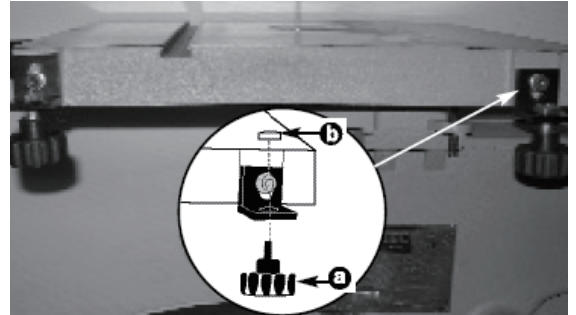

Insert the square nut A of the first front mounting bracket into the T-slot of the front rail B .

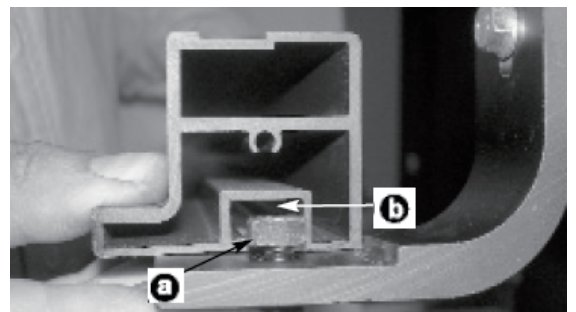

Then, slide the rail onto the second square nut A.

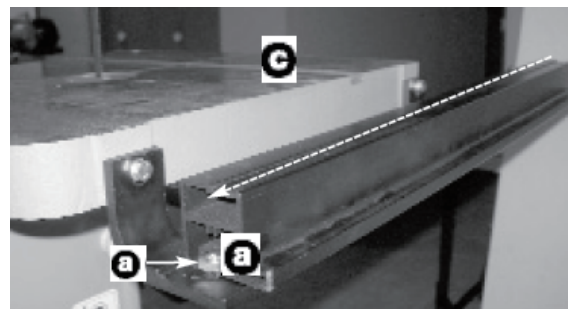

Insert the square nut A of the first rear mounting bracket into the T-slot of the rear rail B .

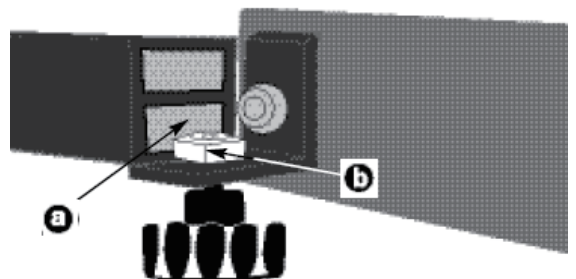

Then, slide the rail up to the second square nut A.

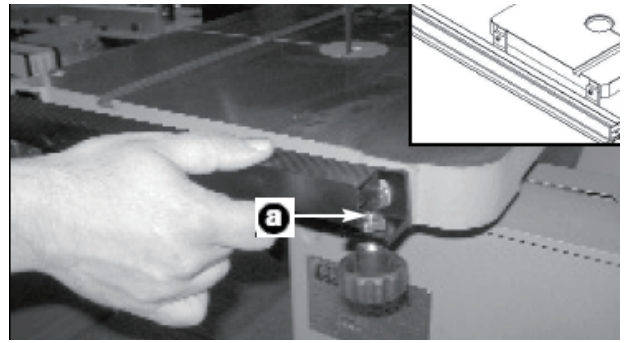

Position the rails A to the left or right of the table B, depending upon the size of your bandsaw C i.e. the space between the frame of the saw and the blade (see image left), and your personal preferences, then tighten the nuts to lock the rails in position

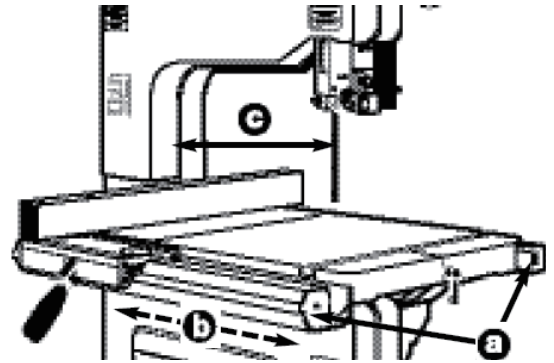

Position the fence firmly down on top of the front rail.

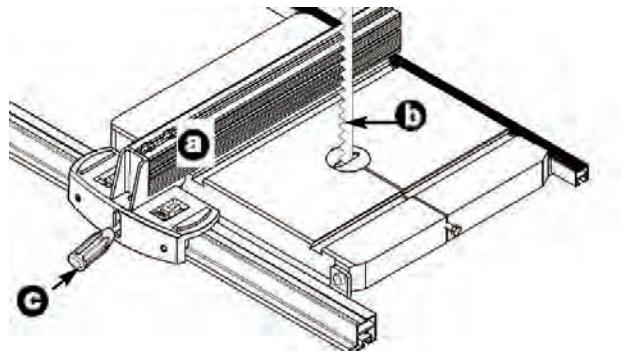

With a 3 mm Allen key, unscrew and remove the screw A that holds the pointer B into the right pointer's window C of the fence base.

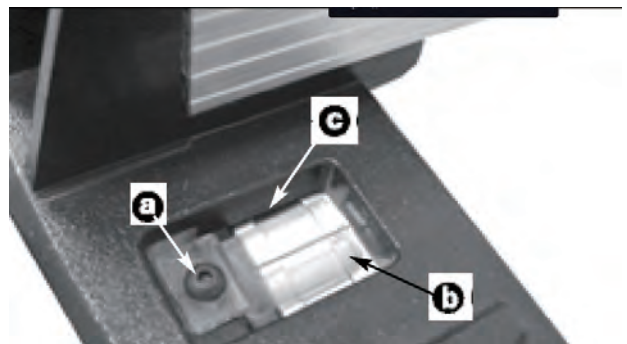

Make a pencil mark on the rail, in line with the pointer's center mark. Then, unlock the fence and put aside the pointer, screw and fence for now.



Cut the measuring tape between both zeros A .
Remove the backing strip from the first half of the measuring tape (the one with the zero on the left) and carefully install along the rail slot, using your pencil mark as the zero-point of the tape .
Trim off excess tape B with a knife or scissors.

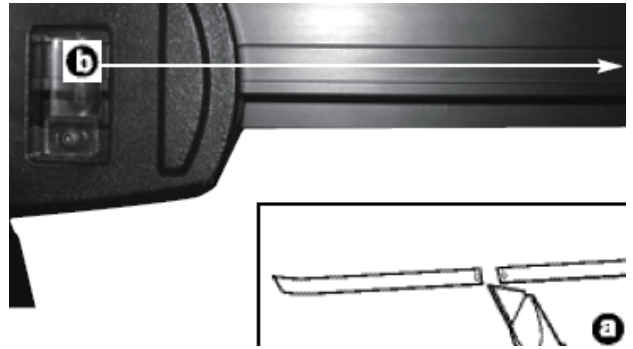

Reinstall the fence on the front rail and lock it down. Then, reinstall the pointer (place the screw in the middle of the hole to allow maximum adjustment capacity on the left or right afterward), and slide the pointer right or left, so that its center mark is in line with the zero-point of the tape. Tighten the screw to lock the pointer in place.

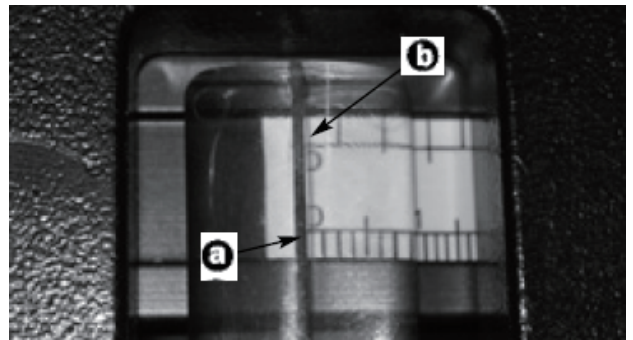

Unlock the guide fence and repeat steps 1 to 5 with the fence to the left of the blade this time, aligning the center mark of the left pointer with the zero of the second half of the measuring tape.

VERTICAL ADJUSTMENT OF THE FENCE 90° TO THE TABLE

Place a machinist square on the table against the fence (See Step 4 below) and, either by eye or with a feeler gauge, look for a gap between the square and the fence (bottom and top) or the table. If needed, adjust as follows.

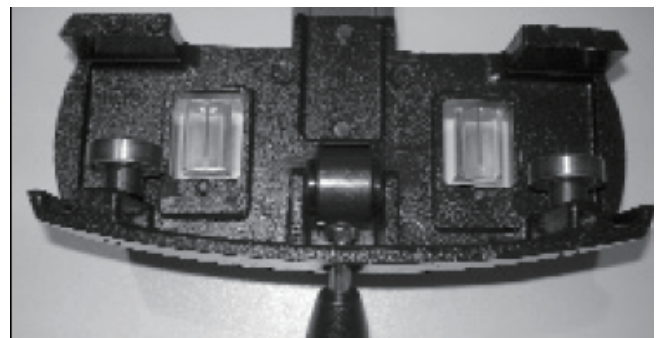

With a 5 mm Allen key, loosen the set screw (without removing it).

Put the fence back on the rails, but do not engage the locking handle to lock the fence.



Reposition the square on the table against the fence as a reference.

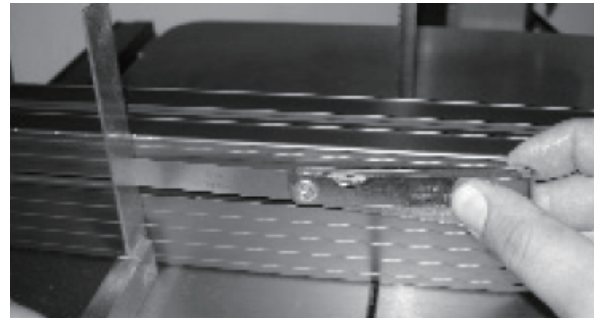

With a flat head screwdriver, slowly turn the screw A (eccentric shaft) on the fence base. This will tilt the fence slightly, allowing you to eliminate the gap between the square and either the fence or the table.

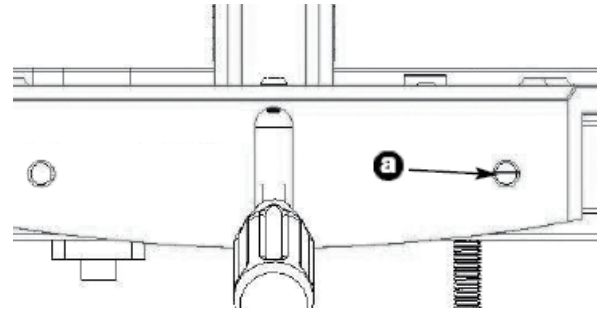

With the fence adjusted 90° to the table, remove it from the rails, turn it up side down and retighten the set screw to lock the fence in place.

ALIGNMENT OF THE FENCE PARALLEL TO THE MITER SLOT

To make satisfactory rip cuts, your fence must be aligned perfectly parallel with the miter slot in the table. Slide the fence over to the T-slot on your saw, as shown in the second diagram. Lock down the fence handle and make a visual check to verify if the fence is parallel with the T-slot along its entire length. You can also place a small block of wood, upright into the T-slot and slide it from front to back checking its distance from the face of the fence.

If the fence is not parallel, it can be adjusted as follows:

Make sure the guide fence is locked on the rails (locking handle down).

With a 8 mm Allen key, loosen (without removing) both screws A that attach the fence to the fence base.

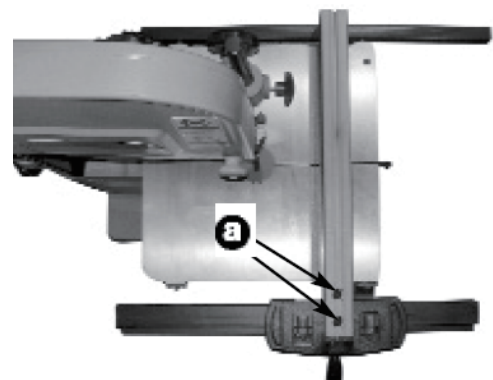

Manually adjust the fence B , so that it is parallel with the miter slot C .



Hold the fence in place with one hand and tighten the first screw C.

If needed, adjust a little further with the remaining bit of play, then tighten the second screw D.

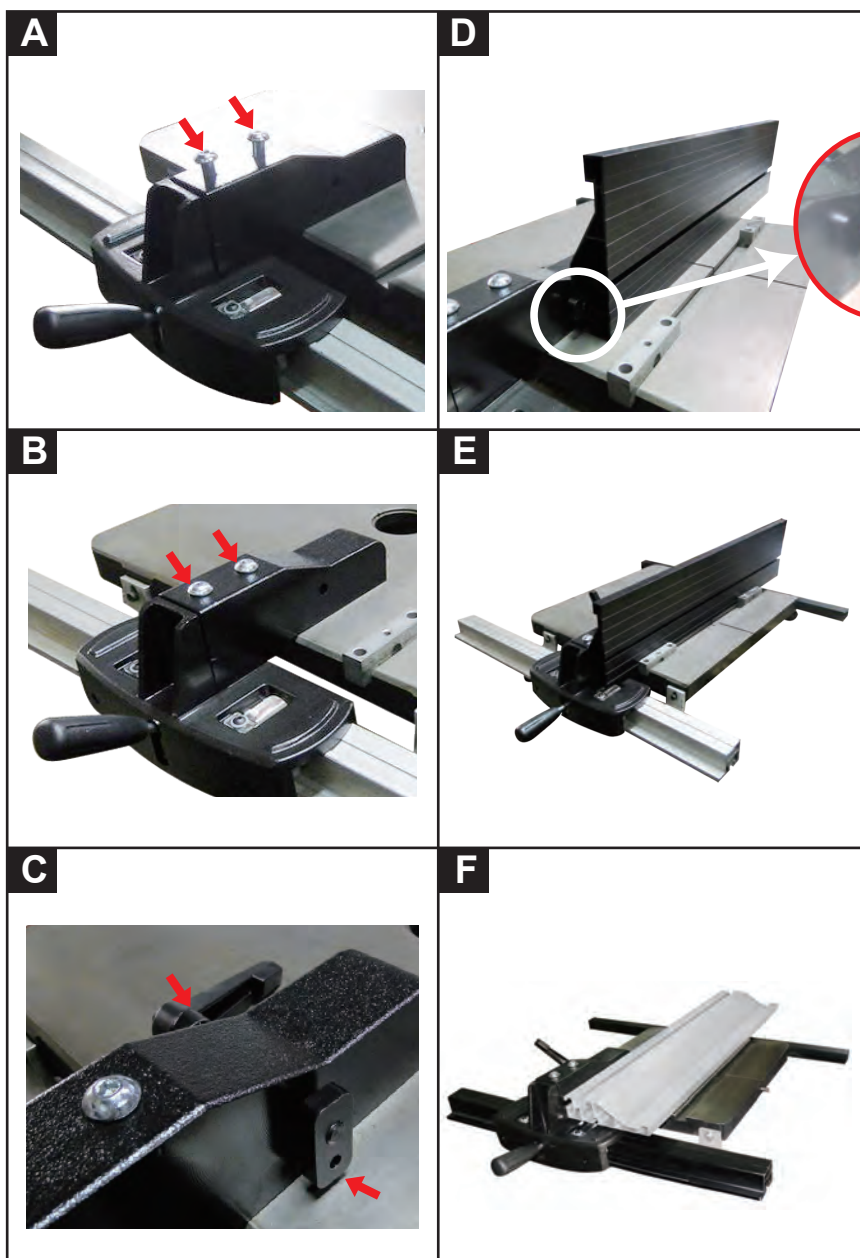
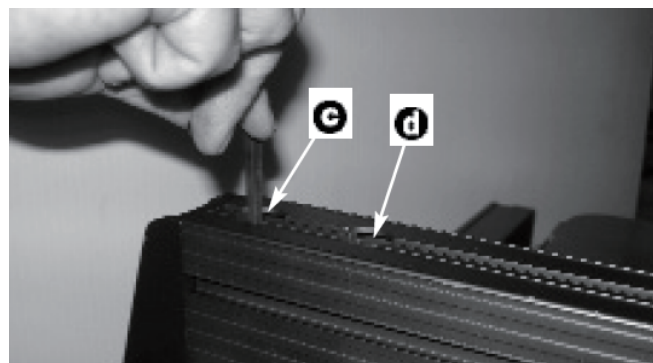

S TYPE BANDSAW BLADE GUIDE MANUAL



Adjust the positioning of the upper thrust bearing:



Note: Upper guide adjustment shown. Lower guides are similar. Adjusting the bearing or block is the same procedure. The difference will be the set dimension.

1. Disconnect the saw from the power source.
2. If not already done, adjust the blade tension and tracking.
3. Lower the blade guide assembly so that it is about 2" (50mm) above the table.
4. Loosen the set screw (A) to allow the guide block to slide side to side.
5. Place a feeler gauge between the bearing and the blade.
 - a. Guide Bearing = 0.01"-0.02" (0.25-0.5mm)
 - b. Ceramic Guides = 0.005"-0.007" (.127-.177mm)
6. Slide the block up to the feeler gauge and blade without deflecting the blade.
7. Hold the block in position and tighten the set screw (A).
8. Repeat the steps for the other side (B).
9. Recheck the gap between the blade and the guides taking note that the gap is equal on both sides and that the guide are not deflecting the blade.
10. Check that the guides are behind the blade teeth 1/64"-1/32" (mm).
11. If the guides are too close or far from the teeth, loosen set screw (D) and slide the entire guide assembly forward or aft until the front edge of the guide is within the set dimension behind the blade teeth.

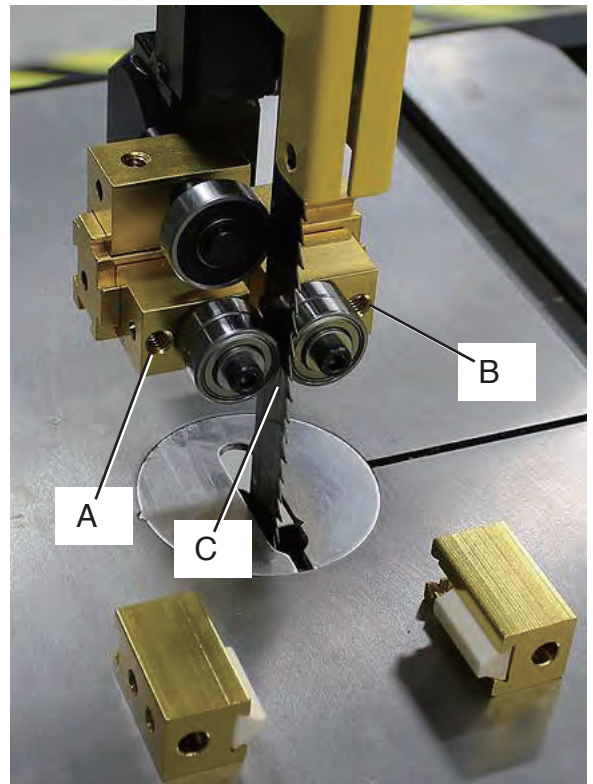

Thrust Bearing Adjustment



Note: Upper thrust bearing shown. Lower thrust bearing is similar.

1. Loosen the set screw (E) (hidden) to allow the thrust bearing block to slide side to side.
2. Slide the block to position the outer bearing cage just past the edge of the blade (F). You will just barely see the edge of the bearing side shield material.
3. Hold the block in position and tighten the set screw (E).
4. Loosen the set screw (G) and slide the bearing shaft forward or aft as needed until the edge of the bearing just touches the spine of the blade without deflecting the blade.
5. Hold the shaft in position and tighten the set screw (G).
6. Adjust the lower thrust bearing using the same steps.

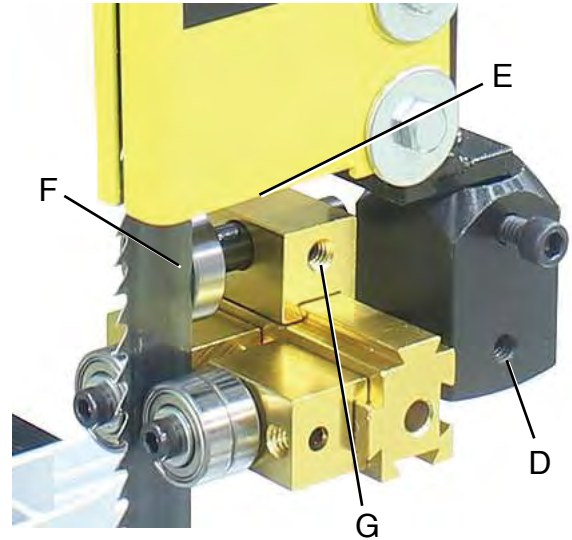

1. Change the lower S guide on 14" bandsaw

a. Put and fasten the plate on the base first.



b. Put and fasten the S blade guide on the plate.

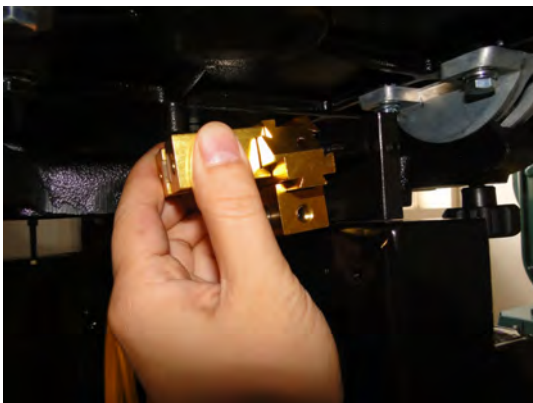

2. Change the new upper S guide on 14" bandsaw

a. Drill two holes on the guide bar

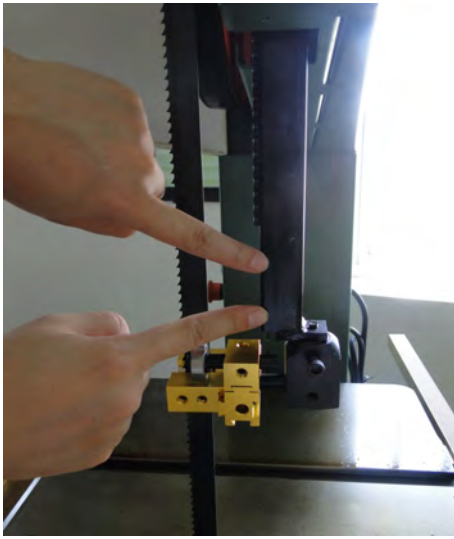

b. Use the extra plate and screws and washers

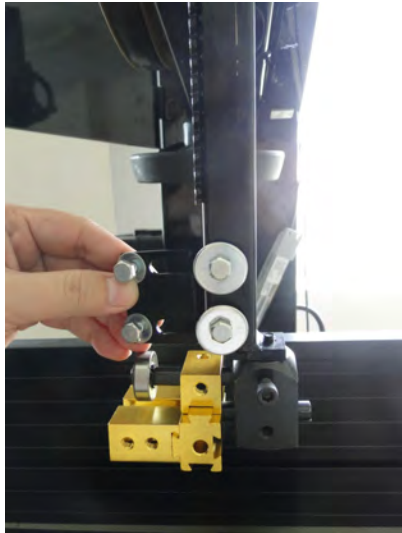

c. Fasten the original blade guard on the plate

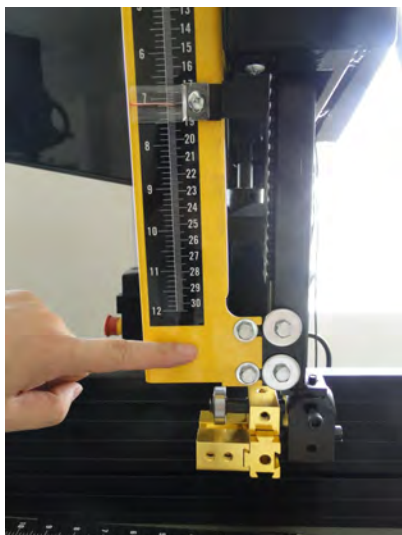

PARTS LIST FOR MI-92300A 、MI-92302

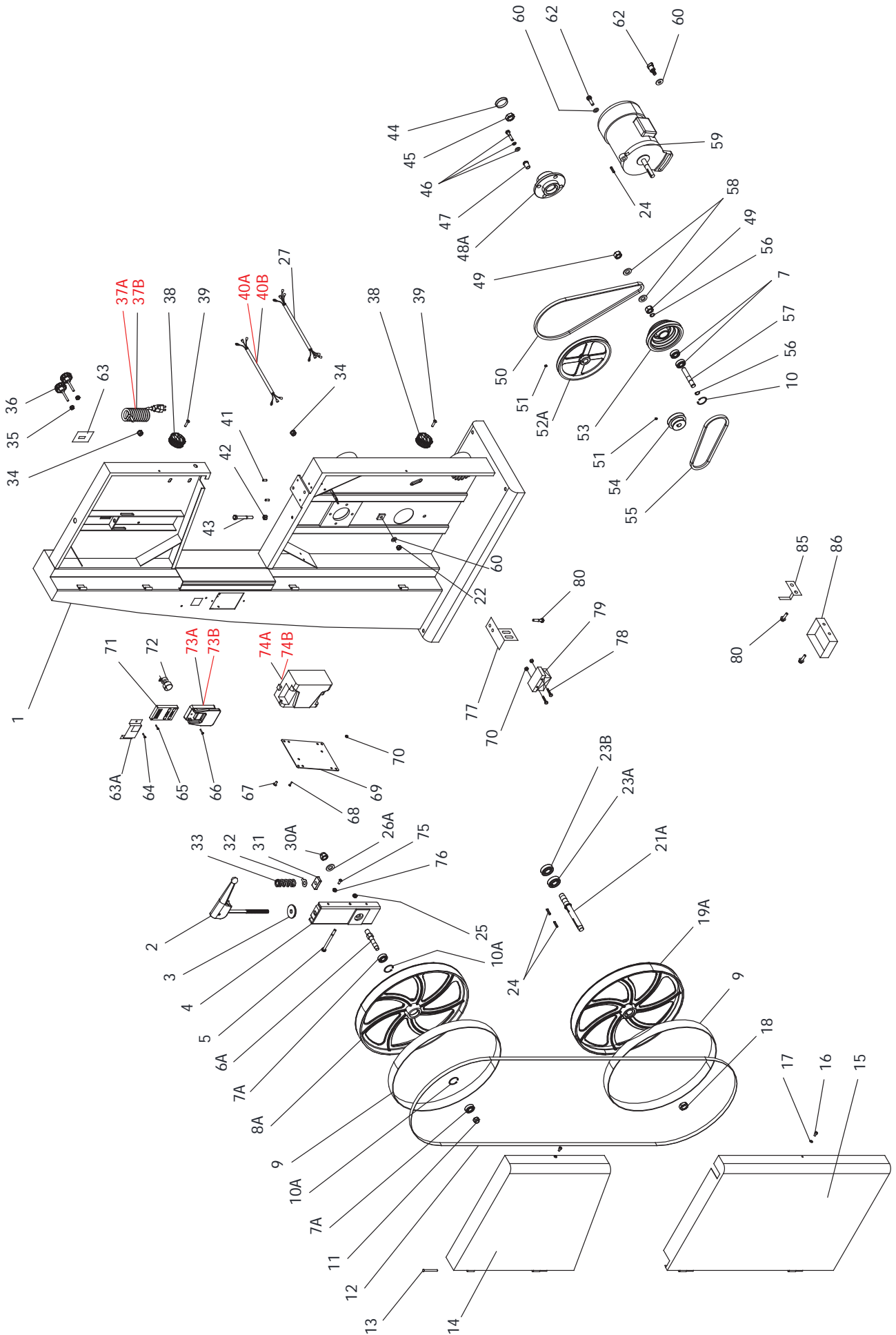

PARTS LIST FOR MI-92300A 、MI-92302

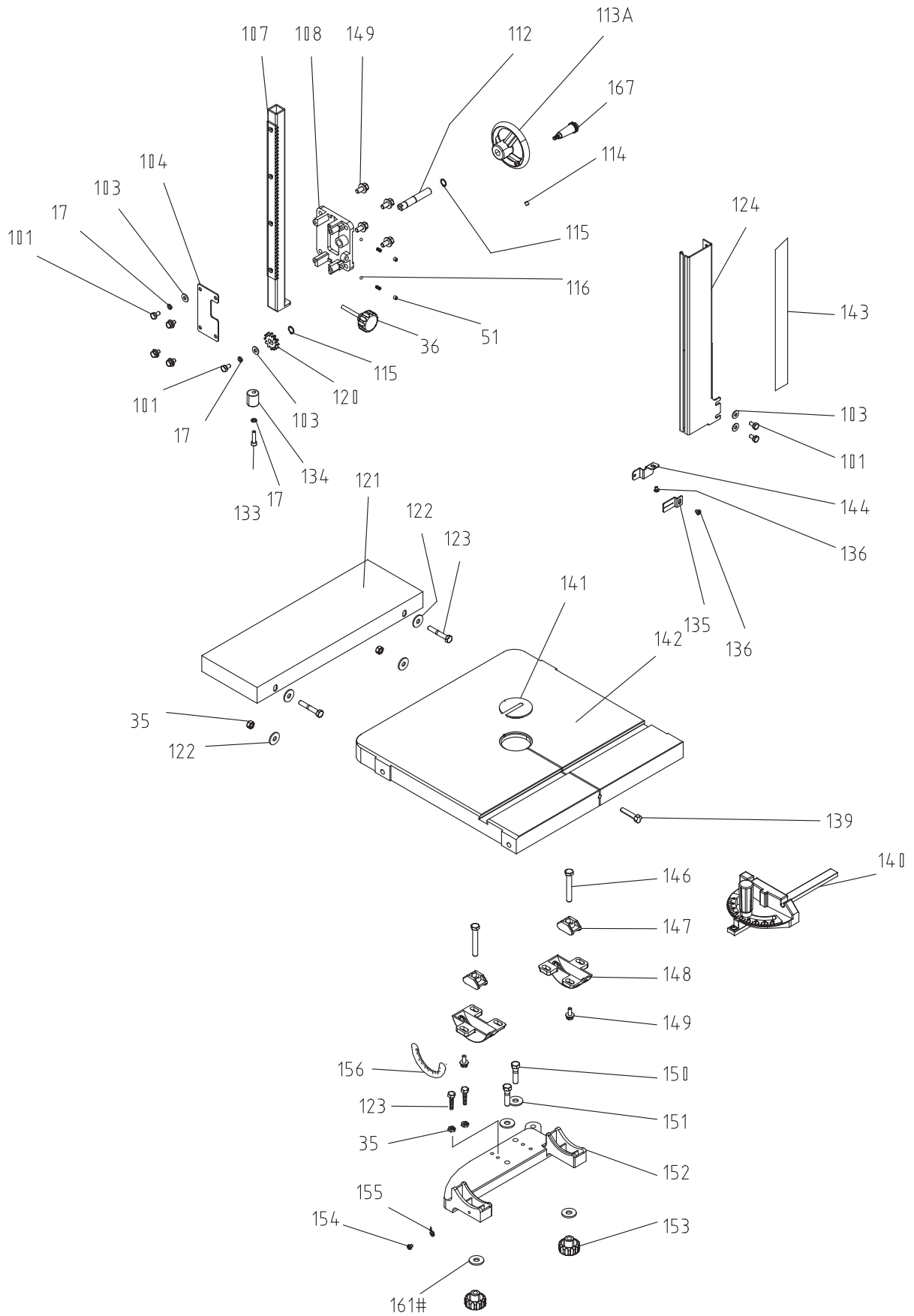

PARTS LIST FOR MI-92300A & MI-92302

REF	DESCRIPTION	REF	DESCRIPTION
MI-92300A-001	BODY	MI-92300A-049	HEX BOLT 5/8"-11P
MI-92300A-002	QUICK HANDLE BAR	MI-92300A-050	V-BELT A41
MI-92300A-003	T TYPE WASHER	MI-92300A-051	SET SCREW 1/4-20P*1/4"
MI-92300A-004	UPPER WHEEL BRACKET	MI-92300A-052A	WHEEL PULLEY
MI-92300A-005	HEX BOLT-M8*110mm	MI-92300A-053	IDLER PULLEY
MI-92300A-006A	UPPER WHEEL SHAFT 17MM	MI-92300A-054	MOTOR PULLEY
MI-92300A-007	BEARING 6202ZZ	MI-92300A-055	V-BELT A30
MI-92300A-007A	BEARING	MI-92300A-056	EXTERNAL RETAINING RING S15
MI-92300A-008A	Upper Wheel - Cast Iron	MI-92300A-057	SHAFT
MI-92300A-009	WHEEL PROTECTOR(TIRE)	MI-92300A-058	FLAT WASHER 5/8"
MI-92300A-010	INTERNAL RETAINING RING R35	MI-92300A-059	MOTOR
MI-92300A-010A	INTERNAL RETAINING RING R40	MI-92300A-060	FLAT WASHER 3/8"
MI-92300A-011	RETAINER NUT 1/2"-P12	MI-92300A-062	HEX BOLT 3/8*1-3/4"
MI-92300A-012	BLADE 133" LONG	MI-92300A-063	TENSION LABLE
MI-92300A-013	HINGE PIN	MI-92300A-063A	SWITCH COVER
MI-92300A-014	UPPER GUARD	MI-92300A-064	PHILLIPS FLAT HEAD SCREW M4*6
MI-92300A-015	LOWER GUARD	MI-92300A-065	PHILLIPS HEAD SCREW M3*18
MI-92300A-016	CAP SCREW 1/4"-20P*3/8"	MI-92300A-066	PHILLIPS HEAD SCREW 3/16*3/4
MI-92300A-017	LOCK WASHER 1/4"	MI-92300A-067	PHILLIPS FLAT HEAD SCREW 1/4*1/2"
MI-92300A-018	HEX NUT 3/4"-16P(L.H.)	MI-92300A-068	PHILLIPS FLAT HEAD SCREW 3/16*1/2"
MI-92300A-019A	LOWER WHEEL -CAST IRON	MI-92300A-069	CONTROLLER COVER PLATE
MI-92300A-021A	LOWER WHEEL SHAFT	MI-92300A-070	HEX NUT 3/16"
MI-92300A-022	LOCK NUT 3/8"-16P	MI-92300A-071	MOTOR INVERTER SWITCH
MI-92300A-023A	BEARING	MI-92300A-072	SPEED DIAL
MI-92300A-023B	BEARING 6005ZZ	MI-92300A-073A	SWITCH W/LARGE STOP FOR MI-92300A_220V/1PH
MI-92300A-024	KEY 5*5*35MM	MI-92302-073B	SWITCH W/LARGE STOP FOR MI-92302_208V/3PH
MI-92300A-025	NYLON NUT M8-P1.25	MI-92300A-074A	AC MOTOR CONTROLLER FOR MI-92300A_220V/1PH
MI-92300A-026A	SPRING WASHER	MI-92302-074B	AC MOTOR CONTROLLER FOR MI-92302_208V/3PH
MI-92300A-027	MOTOR CORD	MI-92300A-075	HEX BOLT 5/16*3/4"
MI-92300A-030A	HEX NUT 5/8"	MI-92300A-076	HEX NUT 5/16"-18P
MI-92300A-031	NUT	MI-92300A-077	BRUSH BASE
MI-92300A-032	BLADE TENSION POINTER	MI-92300A-078	PHILLIPS FLAT HEAD SCREW 3/16*1-1/2"
MI-92300A-033	SPRING	MI-92300A-079	BRUSH
MI-92300A-034	STRAIN RELIEF	MI-92300A-080	HEX BOLT 1/4-20P*3/4"
MI-92300A-035	HEX NUT 5/16"-18P	MI-92300A-085	HOLDER
MI-92300A-036	KNOB 5/16-18X2"	MI-92300A-086	TOOL TRAY
MI-92300A-037A	POWER CORD FOR MI-92300A_220V/1PH	MI-92300A-101	HEX BOLT 1/4-20P*3/8"
MI-92302-037B	POWER CORD FOR MI-92302_208V/3PH	MI-92300A-103	FLAT WASHER 1/4-16*1.2mm
MI-92300A-038	GUARD LOCKING KNOB	MI-92300A-104	GUIDE BAR COVER
MI-92300A-039	SPECIAL HIGH CAP SCREW 7x19-1/4"	MI-92300A-107	GUIDE BAR
MI-92300A-040A	CORD FOR MI-92300A_220V/1PH	MI-92300A-108	BRACKET
MI-92302-040B	CORD FOR MI-92302_208V/3PH	MI-92300A-112	PINION SHAFT
MI-92300A-041	PIN 6*16mm	MI-92300A-113A	6" HANDWHEEL
MI-92300A-042	HEX NUT 3/8"-16P	MI-92300A-114	SET SCREW 5/16*3/8"-18P
MI-92300A-043	HEX BOLT 3/8-16P*4"	MI-92300A-115	EXTERNAL RETAINING RING S13
MI-92300A-044	BEARING COVER	MI-92300A-116	BALL
MI-92300A-045	HEX NUT 3/4"-16P	MI-92300A-120	PINION GEAR
MI-92300A-046	HEX BOLT 5/16-18P*1-1/2"	MI-92300A-121	EXTENSION TABLE
MI-92300A-047	ADJUSTING SCREW	MI-92300A-122	FLAT WASHER 5/16"-20
MI-92300A-048A	BEARING BASE	MI-92300A-123	HEX BOLT 5/16*2"

PARTS LIST FOR MI-92300A \ MI-92302

REF	DESCRIPTION	REF	DESCRIPTION
MI-92300A-124	BLADE COVER	MI-92300A-147	TRUNNION CLAMPSHOE
MI-92300A-133	CAP SCREW 1/4*7/8"-20P	MI-92300A-148	TRUNNION
MI-92300A-134	GUIDE POST	MI-92300A-149	HEX BOLT 5/16-18P*3/4"
MI-92300A-135	POINTER	MI-92300A-150	HEX BOLT 3/8*2"
MI-92300A-136	PHILLIPS HEAD SCREW 3/16"-24P*1/4"	MI-92300A-151	FLAT WASHER 3/8"-19
MI-92300A-139	TABLE PIN	MI-92300A-152	TRUNNION SUPPORT BRACKET
MI-92300A-140	MITER GAUGE ASSY	MI-92300A-153	KNOB
MI-92300A-141	TABLE INSERT ALUMINUM 02.08.01	MI-92300A-154	PHILLIPS HEAD SCREW 3/16"-24P*1/4"
MI-92300A-142	TABLE(19MM T-SLOT)	MI-92300A-155	POINTER
MI-92300A-143	SCALE	MI-92300A-156	GUAGE LABEL
MI-92300A-144	POINTER PLATE	MI-92300A-161	FLAT WASHER 3/8"-19
MI-92300A-146	HEX BOLT 3/8-16P*2-1/2"	MI-92300A-167	HANDWHEEL HANDLE

PARTS LIST FOR MI-92300A \ MI-92302

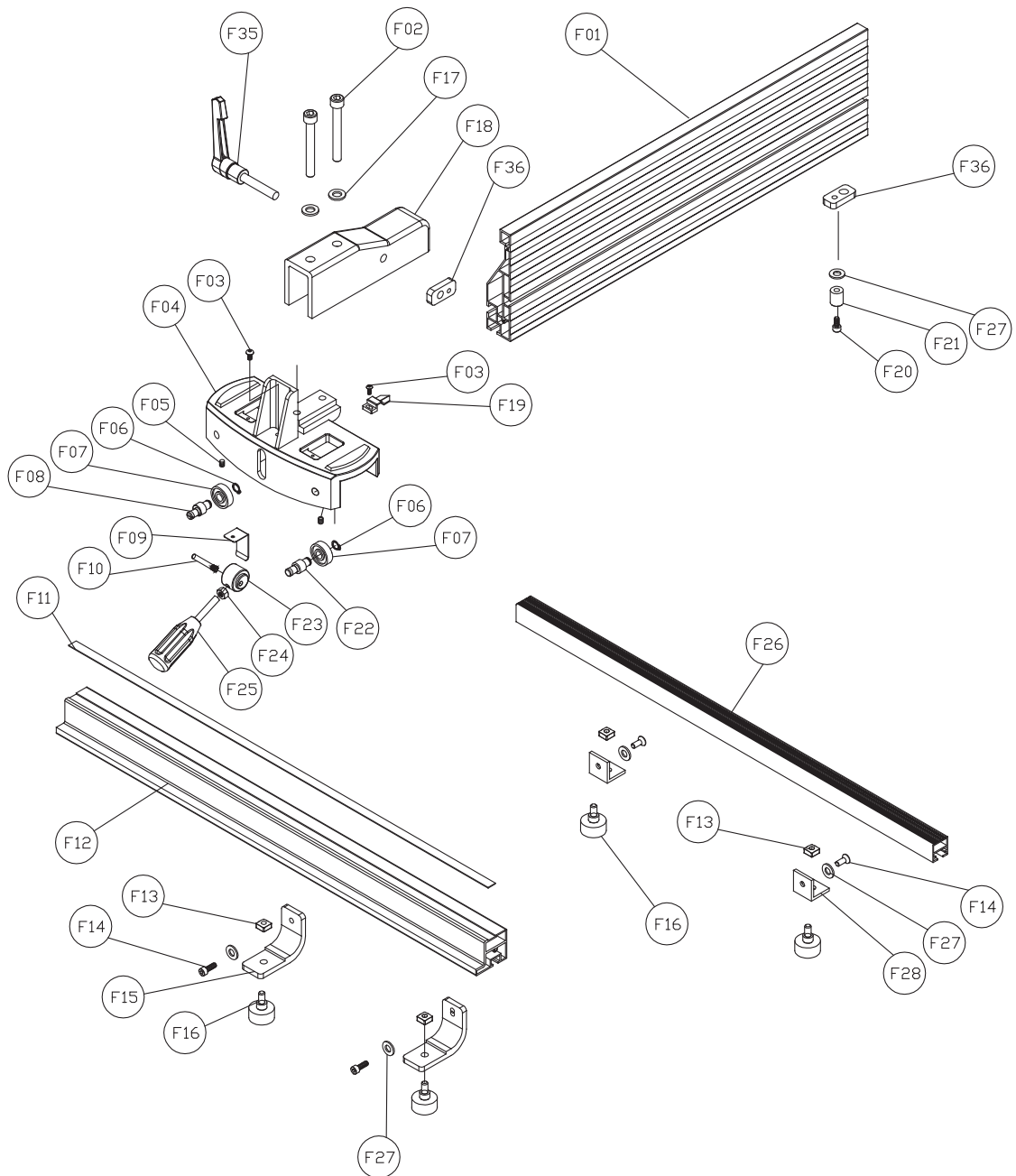

PARTS LIST FOR MI-92300A \ MI-92302

REF	DESCRIPTION	REF	DESCRIPTION
MI-92300A-F01	6" FENCE	MI-92300A-F16	KNOB
MI-92300A-F02	FLAT HEAD CAP SCREW M10	MI-92300A-F17	HEX NUT M6
MI-92300A-F03	FLAT HEAD CAP SCREW M5	MI-92300A-F18	FENCE HOLDER
MI-92300A-F04	FENCE BASE	MI-92300A-F19	POINTER
MI-92300A-F05	SET SCREW	MI-92300A-F20	CAP SCREW
MI-92300A-F06	EXTERNAL RETAINING RING S10	MI-92300A-F21	RUNNER
MI-92300A-F07	BEARING 6200ZZ	MI-92300A-F22	BEARING SHAFT
MI-92300A-F08	ECCENTRIC SHAFT	MI-92300A-F23	LOCK MECHANISM
MI-92300A-F09	PRESSURE PLATE	MI-92300A-F24	HEX NUT
MI-92300A-F10	PIN	MI-92300A-F25	FENCE HANDLE
MI-92300A-F11	FENCE SCALE	MI-92300A-F26	REAR RAIL
MI-92300A-F12	FRONT FENCE RAIL	MI-92300A-F27	FLAT WASHER
MI-92300A-F13	SQUARE NUT	MI-92300A-F28	L BRACKET
MI-92300A-F14	HEX BOLT	MI-92300A-F35	HANDLE LOCK
MI-92300A-F15	L TYPE PLATE	MI-92300A-F36	SPECIAL SCREW

PARTS LIST FOR MI-92300A、MI-92302_S MODEL

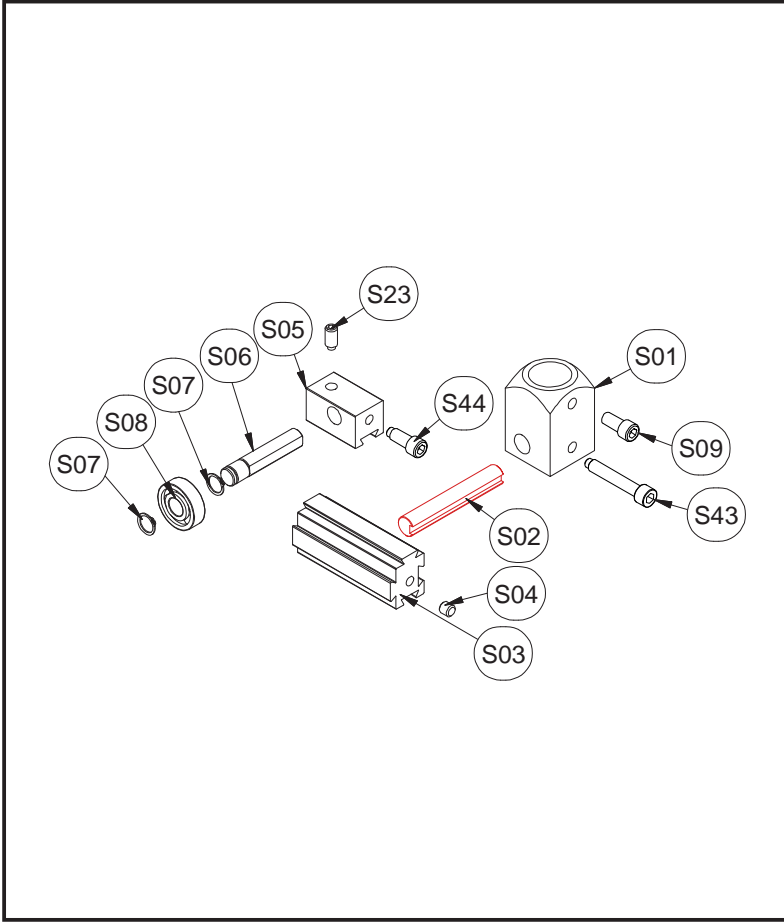

BALL BEARINGS KIT

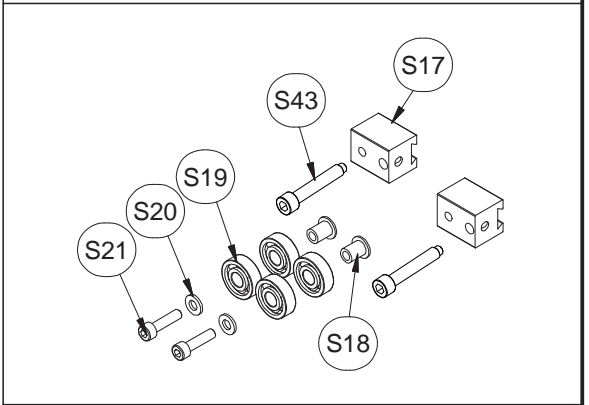

CERAMIC KIT

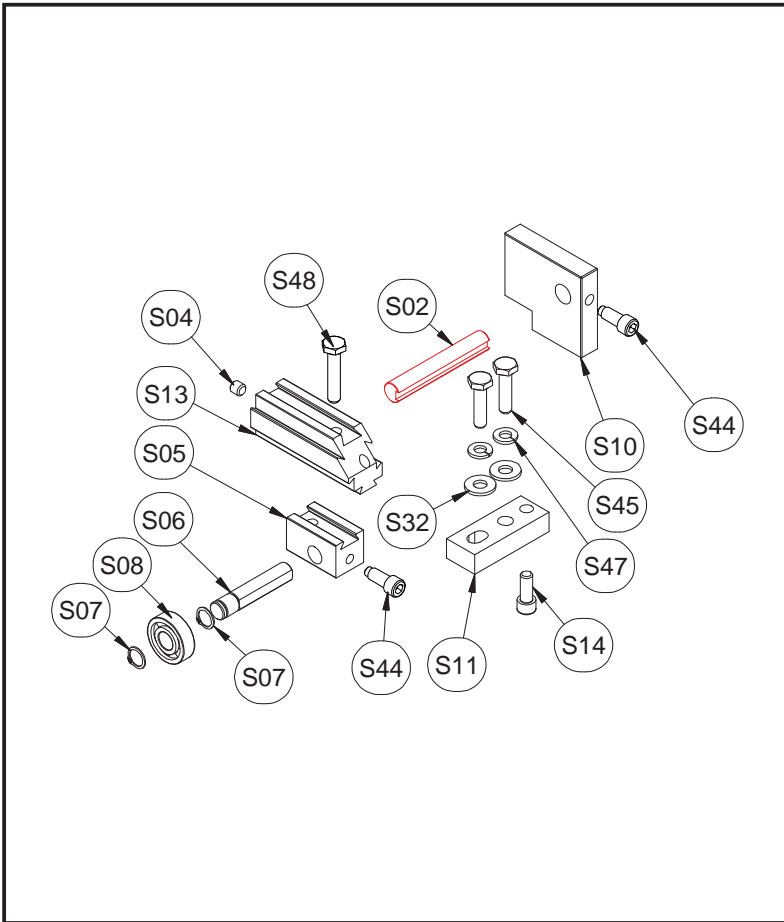
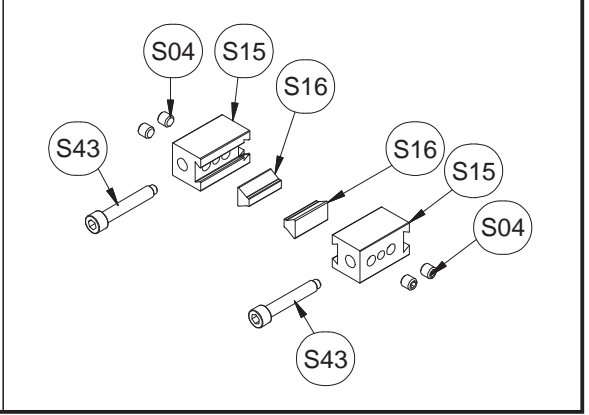

BALL BEARINGS KIT

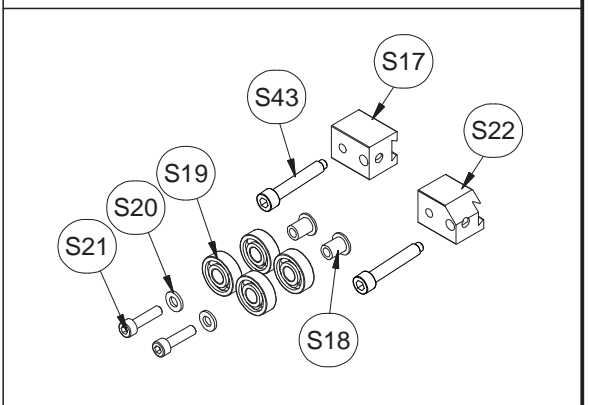



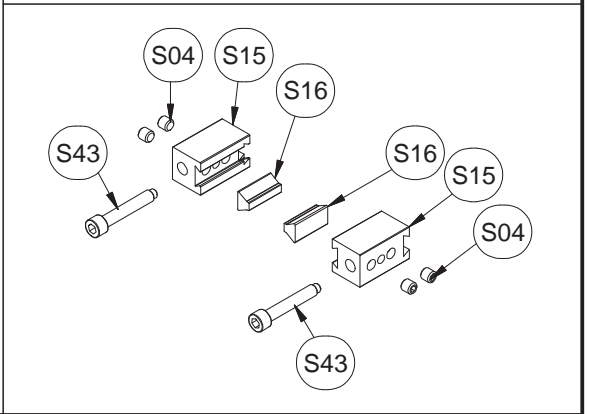











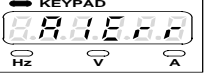

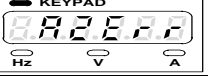
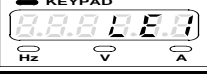
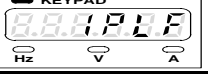
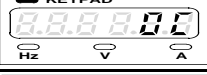

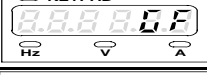



CERAMIC KIT

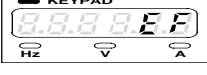
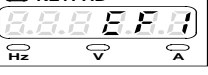
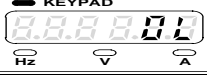







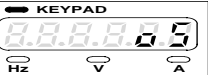



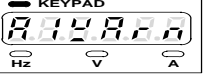

PARTS LIST FOR MI-92300A 、 MI-92302 UPPER DELUXE BEARING GUIDE

PART NO.	DESCRIPTION	PART NO.	DESCRIPTION
MI-92300A-S1	SLEEVE	MI-92300A-S16	CERAMIC GUIDE
MI-92300A-S2	SHAFT	MI-92300A-S17	SLIDING BLOCK - S
MI-92300A-S3	DOVETAIL BLOCK	MI-92300A-S18	BUSHING
MI-92300A-S4	SET SCREW 1/4" x 1/4"	MI-92300A-S19	BALL BEARING 608ZZ
MI-92300A-S5	SLIDING BLOCK - L	MI-92300A-S20	FLAT WASHER 3/16-12
MI-92300A-S6	BEARING SHAFT	MI-92300A-S21	SOCKET HEAD CAP SCREW M5*16mm
MI-92300A-S7	EXTERNAL RETAINING RING S10	MI-92300A-S22	SLIDING BLOCK-CHAMFERING
MI-92300A-S8	BALL BEARING 6000ZZ	MI-92300A-S23	SET SCREW 1/4-20P*1/2"
MI-92300A-S9	CAP SCREW 1/4" x 1/2"	MI-92300A-S32	FLAT WASHER 1/4-16*1.2mm
MI-92300A-S10	BASE - B	MI-92300A-S43	CAP SCREW 1/4*1-1/2"
MI-92300A-S11	BASE - S	MI-92300A-S44	CAP SCREW 1/4*5/8"
MI-92300A-S13	DOVETAIL BLOCK-CHAMFEING	MI-92300A-S45	HEX BOLT 1/4-20P*3/4"
MI-92300A-S14	CAP SCREW 1/4*5/8"	MI-92300A-S47	LOCK WASHER 1/4"
MI-92300A-S15	SLIDING BLOCK OF CERAMIC GUIDE	MI-92300A-S48	HEX BOLT 1/4*1-1/4"

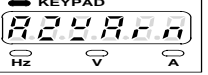
Error Trip Messages of Drive

Display	Description	Display	Description
	EEPROM Error		Keypad connection interrupted
	EEPROM Error 0		Drive overheat
	A/D converter error		Analog input protection 1
	Fuse open		Analog input protection 2
	Under voltage during operation		Input phase loss
	Drive over current		Output phase loss
	Grounding fault		Over voltage
	PID feedback signal error		Operation command fault
	Start command lock 2 (Power ON/OFF)		Start command lock 3 (Local/Remote)
	External fault		External fault 1
	Drive overload		Motor Overload
	Motor over torque 1		Current limit
	Motor over torque 2		System overload
	Motor under torque 1		Motor under torque 2
	Speed deviation		Over speed

Warning Messages of Drive

Display	Description	Display	Description
	Power source under voltage		Keypad cable trip (before connecting)
	Drive output interruption		Keypad cable trip (connected)
	Coast to stop		Analog input warn 1
	Over voltage at stop		Analog input warn 2
	Parameter locked		Parameter Password Unlock
	Communication overtime		Direction command error
	Drive overheat		External overheat