

MAGNUM

INDUSTRIAL

MODEL NO.: MI-15220

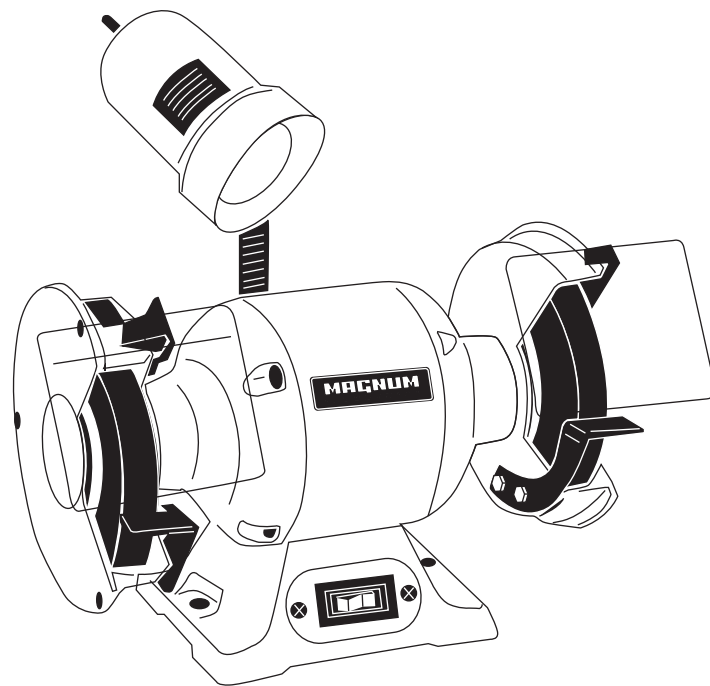

PARTS BREAKDOWN

RULES for SAFE OPERATION

MAGNUM INDUSTRIAL MI-15220 BENCH GRINDER

To help ensure safe operation, please take a moment to learn the how to operate the machine and understand its applications and limitations, as well as potential hazards. KMS Tools and Equipment disclaims any real or implied warranty and holds itself harmless for any injury that may result from the improper use of its equipment.

- Do not operate the machine when tired, distracted or under the effects of drugs, alcohol or any medication that impairs reflexes or alertness.
- Ensure your working area is well lit and free of debris.
- Keep children and visitors at a safe distance when the machine is in operation. Do not permit them to operate the machine.
- Prevent unauthorized or unsupervised use by child proofing and tamper proofing your shop and all machinery with locks, master electrical switches and switch keys.
- Stay alert! Give your work your undivided attention. Even a momentary distraction can lead to serious injury.
- Fine particulate dust is a carcinogen that can be hazardous to health. Work in a well-ventilated area and whenever possible use a dust collector. Protect your face, eyes, ears, lungs and body with suitable personal protective equipment.
- Do not wear loose clothing, gloves, bracelets, necklaces or other jewellery while the machine is in operation.
- Remove adjusting wrenches, tools and other clutter from the machine and the tool rests before using the machine.
- Keep hands well away from the wheels and all moving parts. Use a brush, not your hands, to clear away chips and dust.
- Make sure the grinding wheels are correctly and securely installed on the machine.
- Do not operate the machine if the grinding wheel is worn or damaged.
- Do not force material against the grinding wheel. The machine performs better and more safely when working at the rate for which it was designed.
- Avoid working from awkward or off balance positions. Do not overreach and keep both feet on floor.
- Keep guards in place and in working order. If a guard must be removed for maintenance or cleaning, properly re-attach it before using the machine again.
- Never leave the machine unattended while it is running or with the power on.
- Never stand on machinery. Serious injury could result if the grinder is tipped over or if the wheel is unintentionally contacted.
- Always disconnect the machine from the power source before changing grinding wheels, performing any maintenance, cleaning or servicing or leaving the machine unattended.
- Ensure the switch is in the OFF position before plugging in the power cord.
- Make sure the machine is properly grounded. If equipped with a three-prong plug, use it with a three-pole receptacle. Never remove the third prong.
- Do not use this machine for other than its intended use. If used for other purposes, KMS Tools and Equipment disclaims any real or implied warranty and holds itself harmless for any injury that may result from that use.

PARTS LIST FOR MI-15220

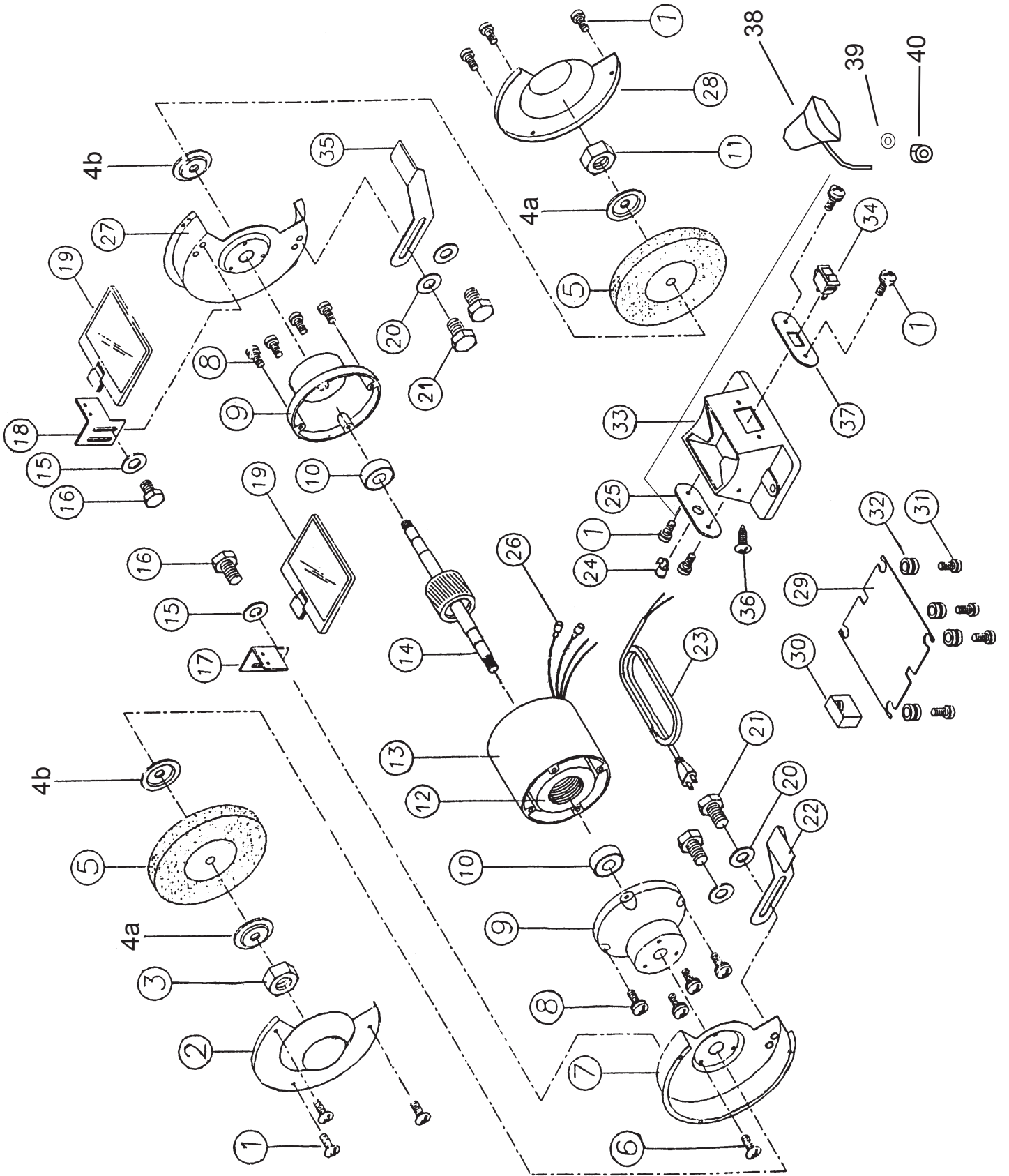

PARTS LIST FOR MI-15220

PART NO.	DESCRIPTION	PART NO.	DESCRIPTION
MI-15220-01	Screw	MI-15220-21	Bolt
MI-15220-02	Left Cover	MI-15220-22	Left Adjustable Rest
MI-15220-03	Nut	MI-15220-23	Wire
MI-15220-04a	Outer Flange	MI-15220-24	Strain Relief
MI-15220-04b	Inner Flange	MI-15220-25	Plate
MI-15220-05	Grinding Wheel	MI-15220-26	Terminals
MI-15220-06	Screw	MI-15220-27	Right Wheel Guard
MI-15220-07	Left Wheel Guard	MI-15220-28	Right Cover
MI-15220-08	Screw	MI-15220-29	Base Plate
MI-15220-09	Motor End Bell	MI-15220-30	Condenser
MI-15220-10	Ball Bearing	MI-15220-31	Screw
MI-15220-11	Nut	MI-15220-32	Pad
MI-15220-12	Motor Stator	MI-15220-33	Base
MI-15220-13	Motor Case	MI-15220-34	Switch
MI-15220-14	Motor Rotor	MI-15220-35	Right Adjustable Rest
MI-15220-15	Washer	MI-15220-36	Screw
MI-15220-16	Bolt	MI-15220-37	Mounting Plate
MI-15220-17	Left Spark Guard	MI-15220-38	Lamp
MI-15220-18	Right Spark Guard	MI-15220-39	Washer
MI-15220-19	Eye Shield	MI-15220-40	Nut
MI-15220-20	Washer		

MAGNUM INDUSTRIAL 5-YEAR LIMITED WARRANTY

Thank you for purchasing Magnum Industrial. Your new Magnum Industrial tool has been designed and manufactured to deliver high-quality performance and dependability over a long service life. Before leaving the factory, every Magnum Industrial product is tested and checked for quality.

5-YEAR LIMITED WARRANTY

Magnum Industrial woodworking and metalworking machinery is backed by a 5-year limited warranty. This warranty covers replacement parts against manufacturer's defect.

- This warranty does not cover parts that have been modified or damaged through misuse, lack of maintenance, negligence, accidents, natural disasters, inadequate dust collection or excessive production demands.
- This warranty does not cover consumable parts or parts that are subject to regular wear and tear during normal operation. Examples of wear and tear parts include drive belts, bearings and switches.
- This warranty does not cover parts damaged during shipping or transportation.

To make a warranty claim, the original purchaser must contact a Magnum Industrial representative and provide documented proof of purchase. Once the representative confirms that the damage has occurred due to manufacturer's defect, Magnum Industrial will ship a replacement part or parts prepaid to the original purchaser. The original purchaser may choose to install the replacement parts or transport the machinery to an authorized Magnum Industrial service centre for installation. Transportation costs are not covered by the warranty.

As determined on a case-by-case basis, parts may need to be inspected by an authorized Magnum Industrial representative before parts are eligible for warranty. In these cases, the original purchaser is responsible for transporting the parts to a representative or an authorized Magnum Industrial service centre.

LABOUR AND TRANSPORTATION COSTS

The original purchaser may choose to transport the machinery to an authorized Magnum Industrial service centre for warranty evaluation. Transportation costs and expenses related to moving machinery to and from carrier vehicles are not covered by the warranty.

Once the machinery has been evaluated by the authorized Magnum Industrial service centre, any parts damaged due to manufacturer's defect will be replaced and installed at no cost. Labour is covered by warranty only when completed by an authorized Magnum Industrial service centre. The warranty does not cover third-party repairs.

ORIGINAL PURCHASER OF THE PRODUCT

This warranty is non-transferable and applies to the original purchaser only. This warranty requires documented proof of purchase.

MANUAL

This manual is a guide for assembling and adjusting this product. It is not a woodworking or metalworking training manual. It is the end user's responsibility to understand how to safely set up, operate, and maintain woodworking and metalworking machinery. Because product specifications can change without notice, some details in this manual may not apply to the product you purchased.

DISCLAIMER

KMS Tools and Equipment and Magnum Industrial holds itself harmless for any injury or property damage that may result from the use of this product.