

## Hinge Boring Machine (MI-77450)



Powerful, sturdy and efficient, the MI-77450 Hinge Boring Machine saves you time when installing Blum-style hinges, drilling the 35 mm centre hole and both 8 mm screw holes in one stroke. Pre-drilling cabinet doors has never been easier!

**One Stroke  
Pre-Drilling for  
Blum-Style  
Hinges**

### Features:

- Powerful 1 HP motor drills through the toughest laminate and solid wood
- Long lever control for effortless action
- Precision work stops allow accurate repeat drilling on multiple work pieces
- Heavy-duty cast-iron construction meets the demands of professional cabinet manufacturers
- Extra-wide open steel stand provides stability and vibration-free operation
- Uses standard 10 mm shank chucks
- Includes one 35 mm carbide bit and two 8 mm carbide bits

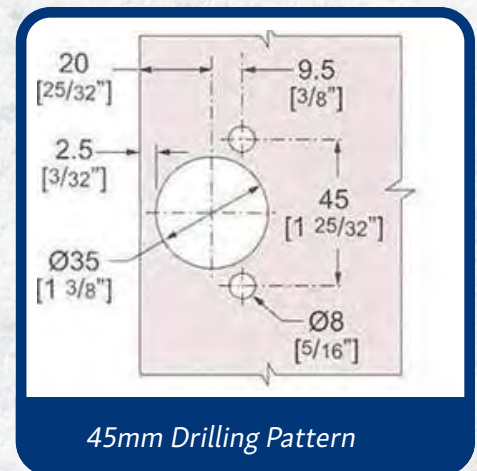

### Specifications:

<b>Motor:</b>	1 HP, 110V, 1 PH, 15A	<b>Max depth of stroke:</b>	4-5/8" (120 mm)
<b>Collet size:</b>	3/8" (10 mm)	<b>Max depth bit to fence:</b>	3-1/2" (88 mm)
<b>Spindle speed:</b>	3,450 RPM	<b>Table size:</b>	31-1/2" x 23-5/8" (800 x 600 mm)
<b>Hinge type:</b>	Blum-style	<b>Base dimensions:</b>	12" x 12" (305 x 305 mm)
<b>Max stock thickness:</b>	5-1/2" (140 mm)	<b>Table height from floor:</b>	33-1/4" (845 mm)
<b>Fence size:</b>	66-1/8" x 105-1/2" (1,680 x 2,680 mm)	<b>Weight:</b>	210 lbs (95 kg)